



WATER HEATER RESTRAINT

Secures & Protects Water Heaters From Earthquakes & Other Natural Disasters



FR-80 Front Tensioning CA State DSA "Accepted Method" for water heater earthquake bracing. Approved for water heaters up to 80 gallons.

- ✔ Complies with all codes
- ✔ High-strength, fire-resistant material, will not rot or rust
- ✔ No sharp edges
- ✔ Pre-assembled with self-drilling lag bolts
- ✔ Fast, easy installation
- ✔ Tested to ICC-ES AC-156

Santa Ana, CA
PATENT 7,103,942

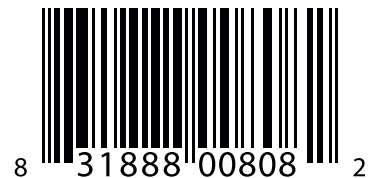



Installation Instructions for FR-Series Water Heater Restraint

1. Find studs. Mark stud center locations on both sides of heater within the top and bottom third of heater. (Bottom strap must be 4 inches above controls.)
2. Screw Lagbolts into studs on marks. Match up buckle & free ends as shown.

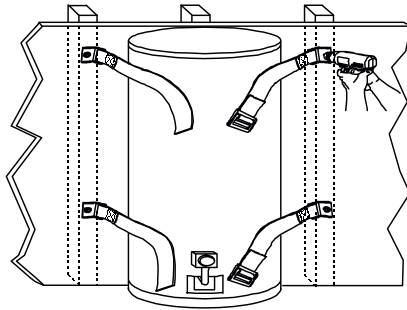

3. Center front buckle on water heater. Buckle is secured to strap as follows; **A.** Thread the strap behind then through the buckle, **B.** Bring strap over the shorter leg's crossbar and back down under the longer leg's bar, **C.** Pull free end of strap tight. Secure remaining strap with clip.

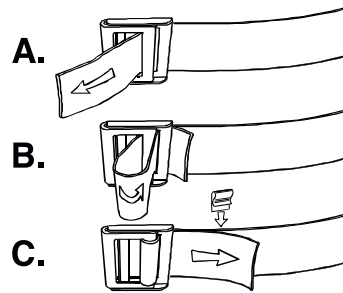

4. Join straps in front by; **A.** Thread the free strap under the front buckle and moveable crossbar, **B.** Bring strap over the crossbar then down under the front bar of buckle, **C.** Pulling free end of strap, cinch tight. Secure remaining strap with clip.

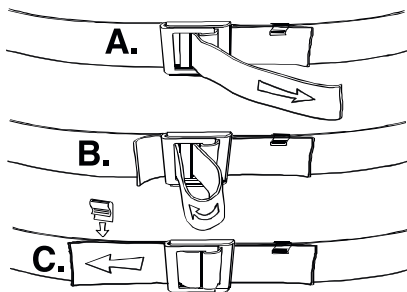

WARNING:

Only experienced or qualified persons should attempt installation. Electrical wiring or pipes may be concealed by wall coverings and if punctured by fasteners may cause serious damage or injury.

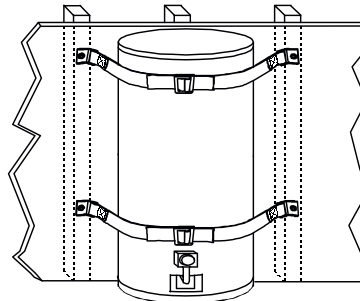

INSTALLATION OPTIONS: (Top View)

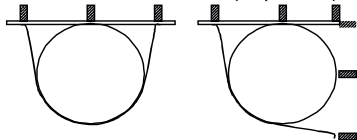

WARRANTY/DISCLAIMER:

Little Firefighter warrants this product to be free of defective material and workmanship for as long as you own the water heater it secures. This is the full extent of our lifetime warranty. It is the responsibility of the user to make sure the restraint is properly installed.

Little Firefighter shall not be liable for unsafe installations.

In some areas it is required to keep heater at least 1" away from the wall. Spacers shall be constructed from standard 2" X 4" wooden boards to provide up to 6 inches of space between the wall and water heater. The spacers shall be located in approximately the same level as the straps (one within the top third of the heater and one within the bottom third) and be solidly affixed to the wooden wall stud. Water heater shall be in contact with wall or spacer. Lag bolts shall be screwed into the wooden wall stud and shall not pass through the spacer. This product may be used unless specifically prohibited by the water heater manufacturer's installation instructions.

Firefighter Gas Safety Products

204 S. Center St. Santa Ana, CA 92703 Tel: (714) 834-0410 Fax: (714) 834-0412



WARNING: This product can expose you to chemicals including Chromium, which are known to the State of California to cause cancer and birth defects or other reproductive harms. For more information go to www.P65Warnings.ca.gov